

PANEL:



STANDING SEAM PANEL

DATE:

5-14-09

DET. #

238C-1

DETAIL:

TRANSVERSE CURB (PLAN VIEW)

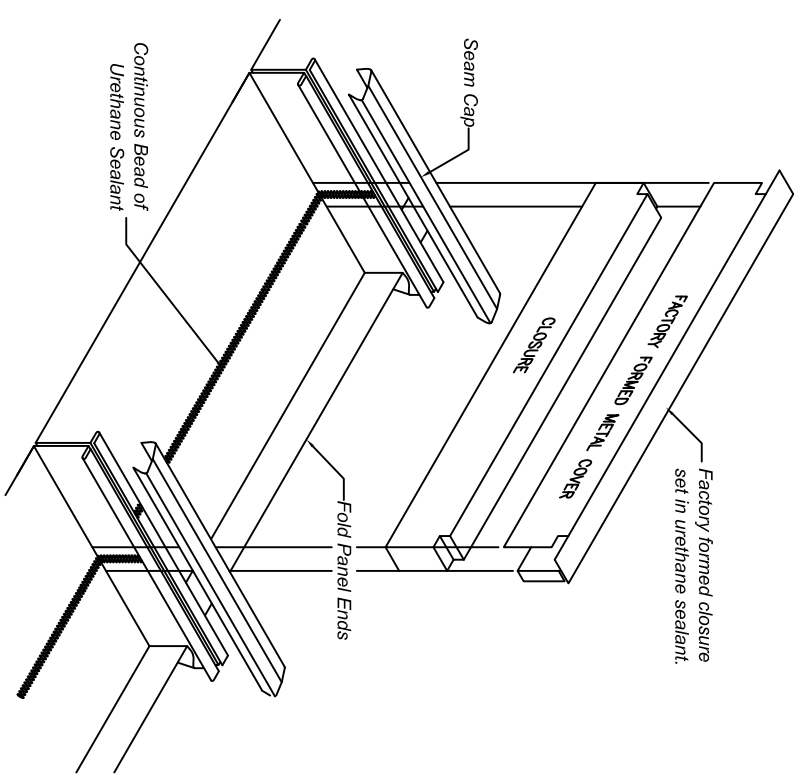
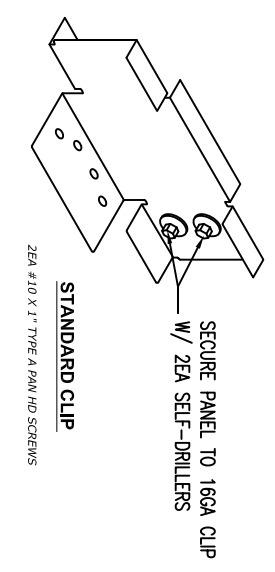
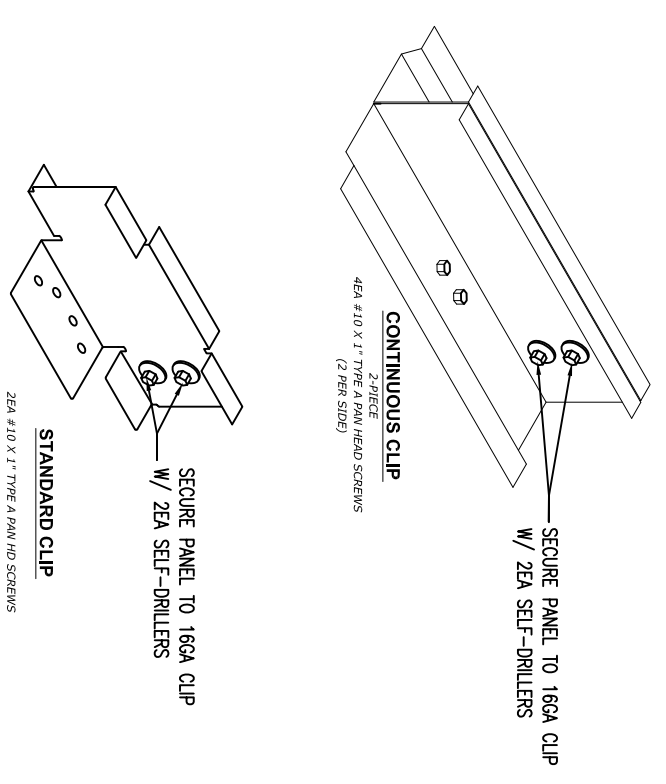
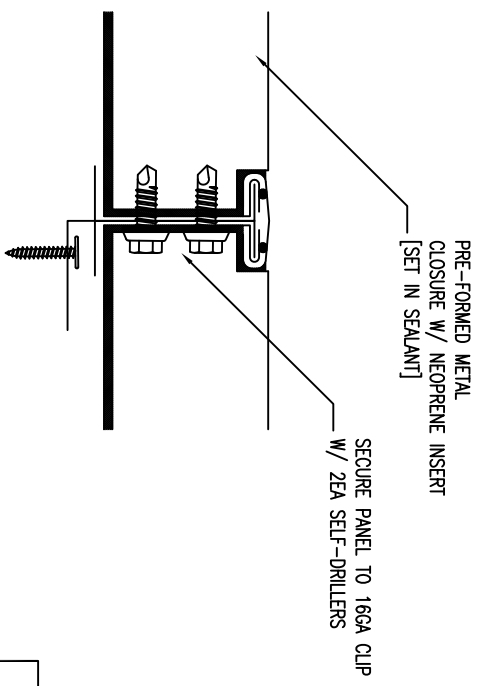
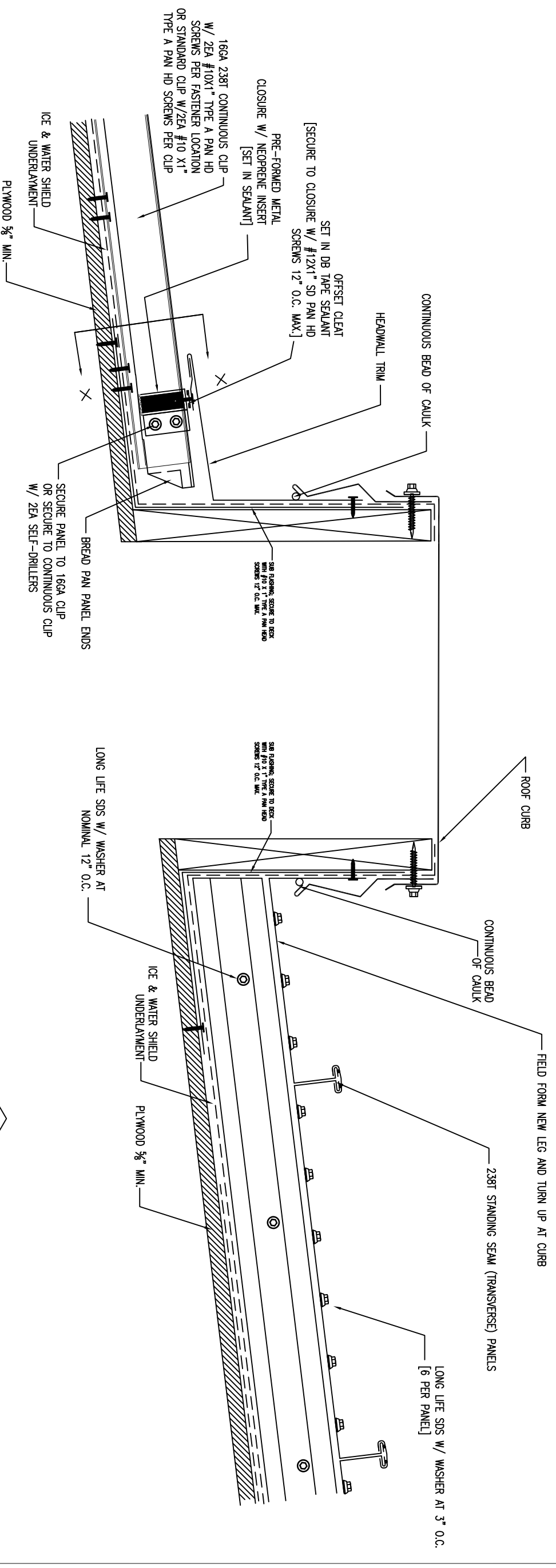

SECTION X - X

Architectural Building Components
 WWW.ARCHMETALROOF.COM
 11625 NORTH HOUSTON
 ROSSLYN ROAD
 HOUSTON, TEXAS 77086
 PHONE: (281) 931-3989
 FAX: (281) 931-3986
 TOLL FREE: 1-800-423-1105

PANEL TYPE:		238T PANEL	
DETAIL DESCRIPTION:		SECTION AT TRANSVERSE CURB	
REVISION	DATE:		
A	5-14-09		
DRAWING NUMBER:		238C-2	

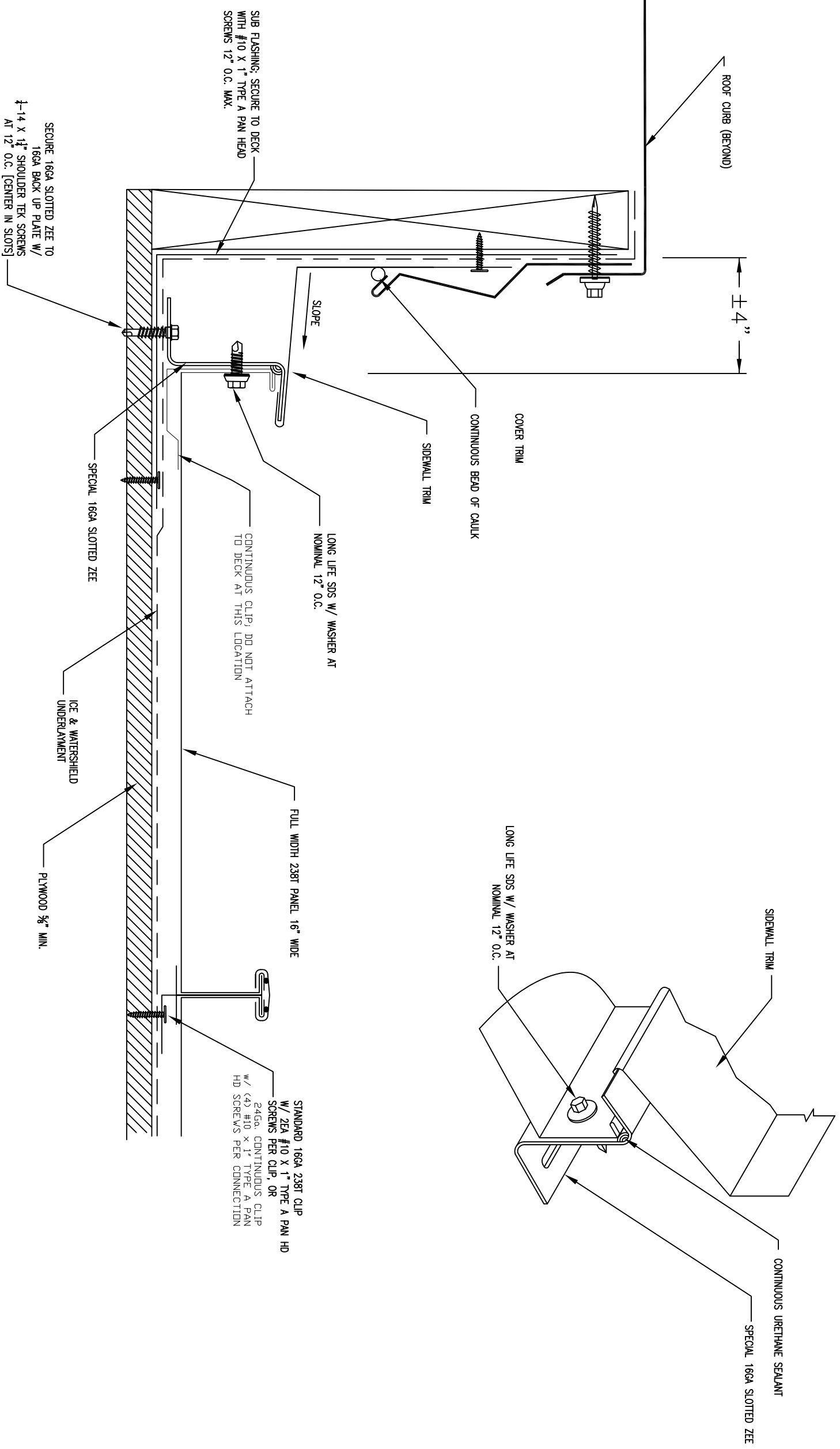

Architectural Building Components
 11625 NORTHERN HOUSTON
 ROSSLYN ROAD
 HOUSTON, TEXAS 77086
 PHONE: (281) 931-3989
 FAX: (281) 931-3986
 TOLL FREE: 1-800-423-1105
 WWW.ARCHMETALROOF.COM

PANEL TYPE:
238T STANDING SEAM
 DETAIL DESCRIPTION:
TRANSVERSE RAKE WALL

REVISION	DATE:
A	5-14-09
DRAWING NUMBER: 238C-3	

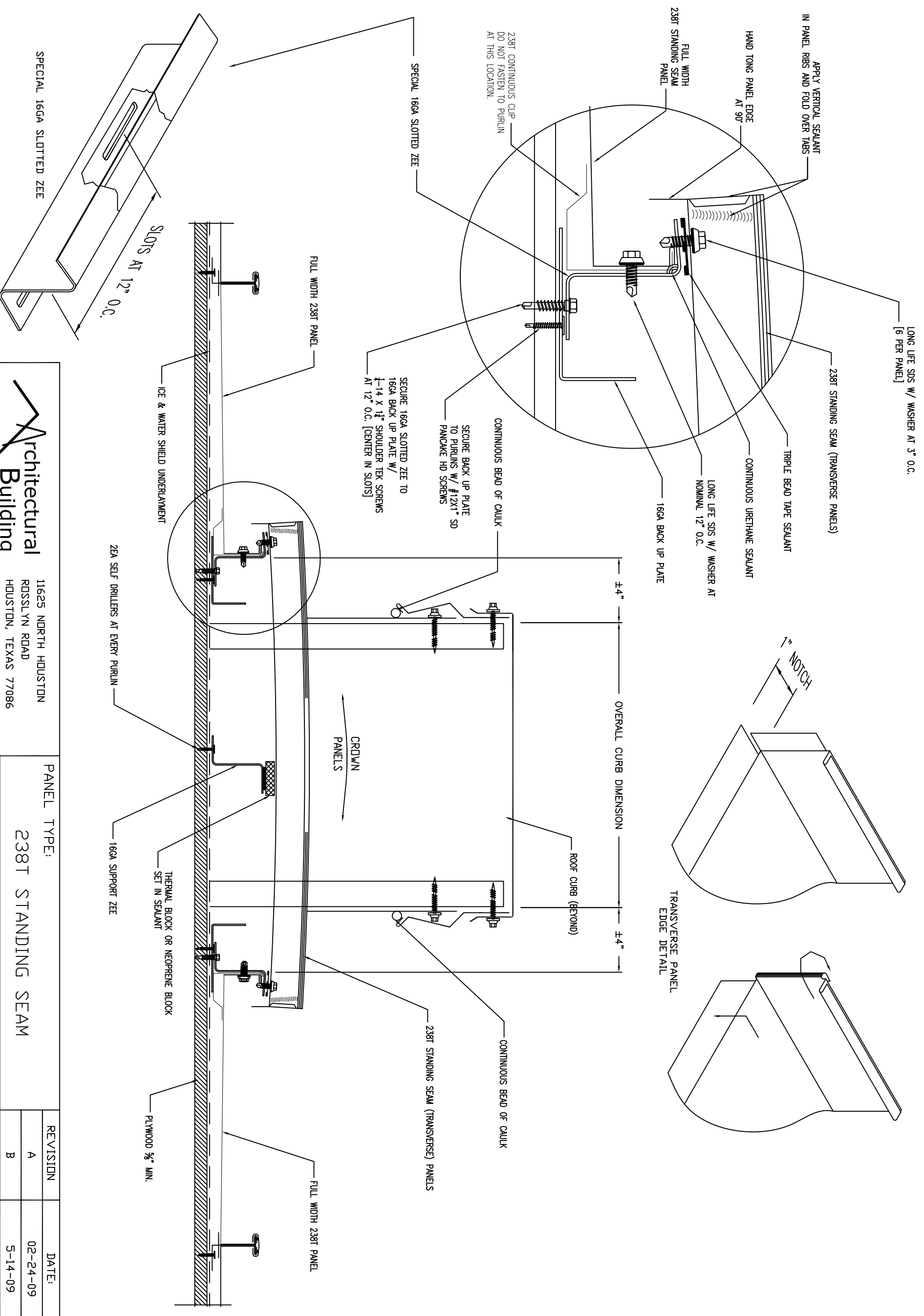

SPECIAL 16GA SLOTTED ZEE

SLOTS AT 12" O.C.

ICE & WATER SHIELD UNDERLAMENT

2EA SELF DRILLERS AT EVERY PURLIN

16GA SUPPORT ZEE

THERMAL BLOCK OR NEOPRENE BLOCK SET IN SEALANT

PLYWOOD 5/8" MIN.

FULL WIDTH 238T PANEL

FULL WIDTH 238T PANEL

CROWN PANELS

ROOF CURB (BEYOND)

±4"

OVERALL CURB DIMENSION

±4"

SECURE 16GA SLOTTED ZEE TO 16GA BACK UP PLATE W/ 1-14 X 1 1/4" SHOULDER TEK SCREWS AT 12" O.C. [CENTER IN SLOTS]

SECURE BACK UP PLATE TO PURLINS W/ #12X1" SD PANCAKE HD SCREWS

CONTINUOUS BEAD OF CAULK

CONTINUOUS BEAD OF CAULK

238T STANDING SEAM (TRANSVERSE) PANELS

238T CONTINUOUS CLIP DO NOT FASTEN TO PURLIN AT THIS LOCATION.

APPLY VERTICAL SEALANT IN PANEL RIBS AND FOLD OVER TABS

LONG LIFE SDS W/ WASHER AT 3" O.C. [6 PER PANEL]

238T STANDING SEAM (TRANSVERSE PANELS)

TRIPLE BEAD TAPE SEALANT

CONTINUOUS URETHANE SEALANT

LONG LIFE SDS W/ WASHER AT NOMINAL 12" O.C.

16GA BACK UP PLATE

238T STANDING SEAM

FULL WIDTH 238T STANDING SEAM PANEL

HAND TONG PANEL EDGE AT 90°

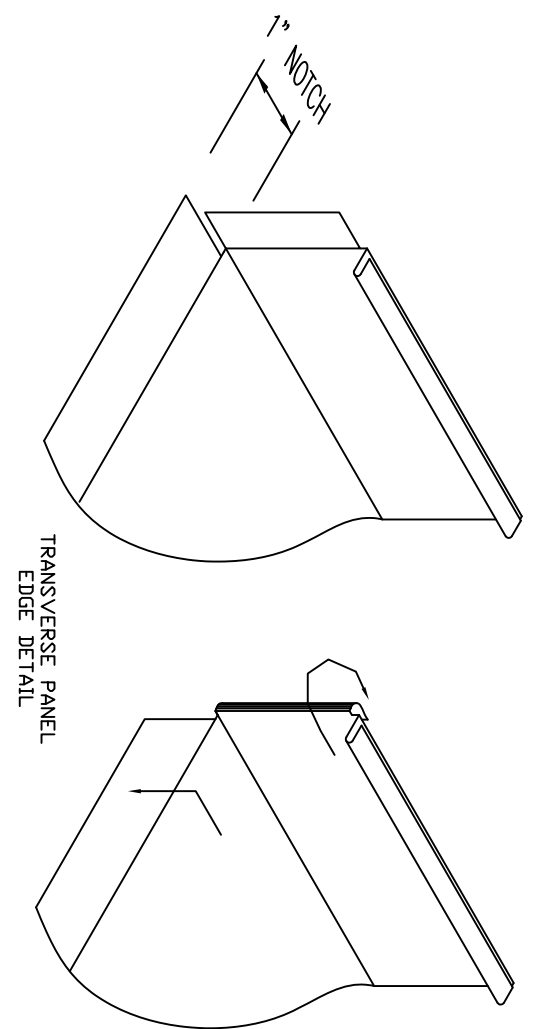

TRANSVERSE PANEL EDGE DETAIL

Architectural Building Components
 WWW.ARCHMETALROOF.COM

11625 NORTH HOUSTON
 ROSSLYN ROAD
 HOUSTON, TEXAS 77086
 PHONE: (281) 931-3989
 FAX: (281) 931-3986
 TOLL FREE: 1-800-423-1105

PANEL TYPE:
 238T STANDING SEAM

REVISION	DATE
A	02-24-09
B	5-14-09

DETAIL DESCRIPTION:
 SECTION AT TRANSVERSE PANEL

DRAWING NUMBER:
 238C-4

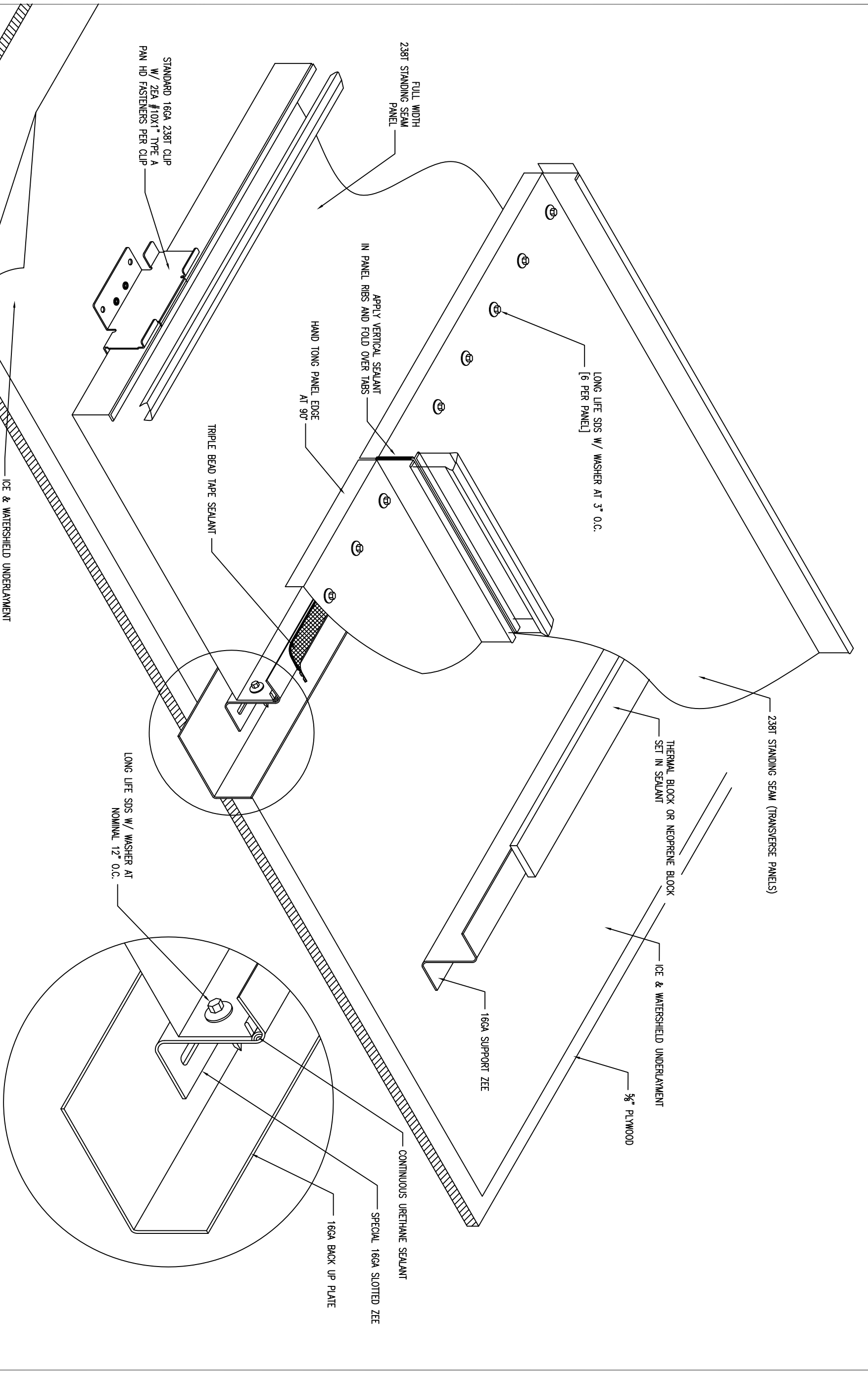

Architectural Building Components
 11625 NORTH HOUSTON
 ROSSLYN ROAD
 HOUSTON, TEXAS 77086
 PHONE: (281) 931-3989
 FAX: (281) 931-3986
 TOLL FREE: 1-800-423-1105
 WWW.ARCHMETALROOF.COM

PANEL TYPE:		238T PANEL	
DETAIL DESCRIPTION:		ASSEMBLY AT TRANSVERSE PANELS	
REVISION	DATE:		
A	5-14-09		
DRAWING NUMBER:		238C-5	