

**TYP CURB DETAIL SECTION B-B**

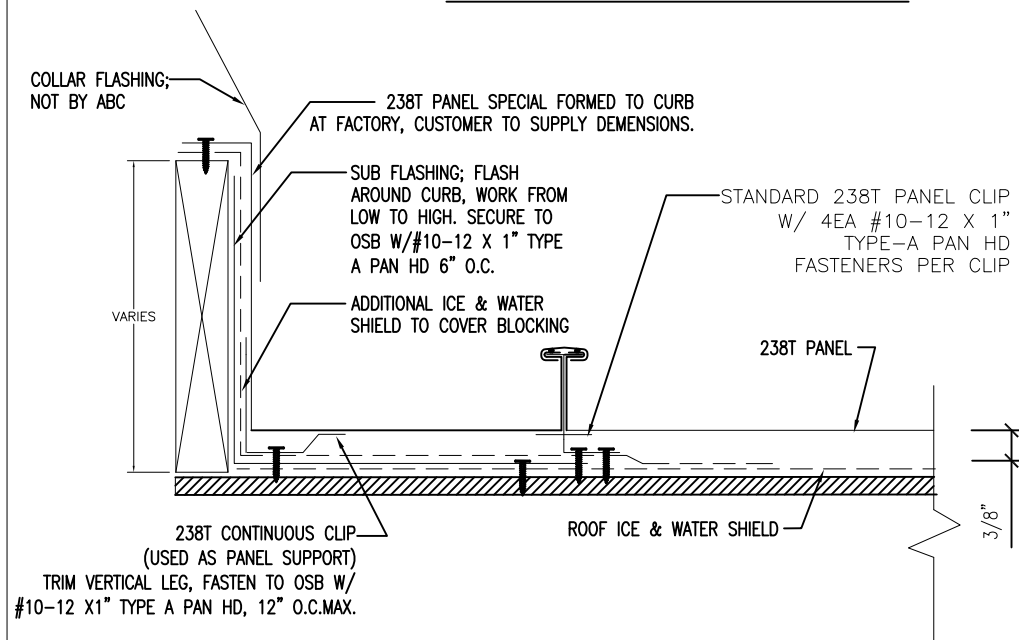

**TYP CURB DETAIL SECTION A-A**

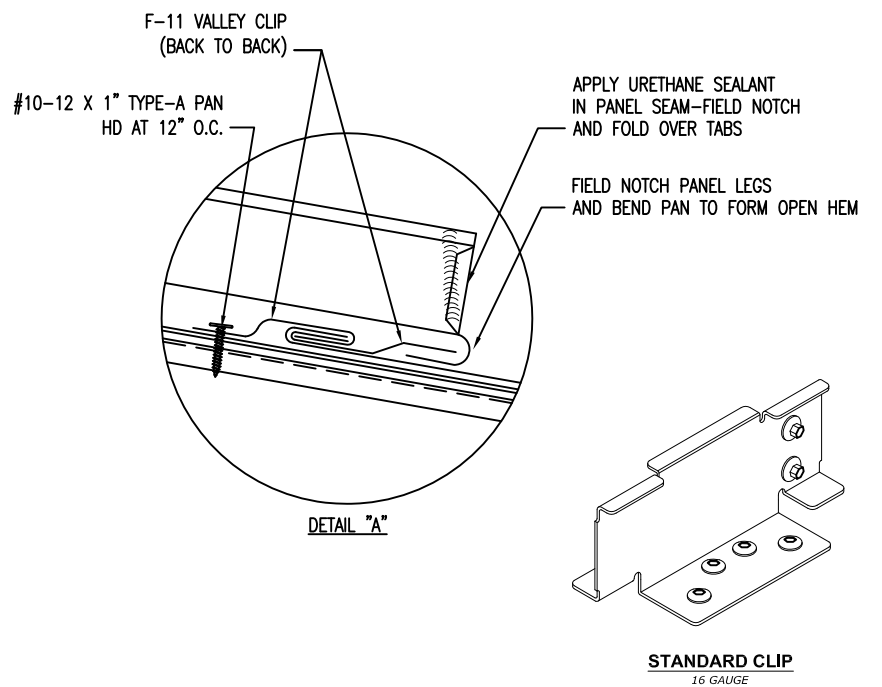

**ALL DIMENSIONS, ANGLES, SECTIONS, DETAILS AND TRIM DIMENSIONS WILL BE VERIFIED IN WRITING, BY THE GENERAL CONTRACTOR OR INSTALLER PRIOR TO FABRICATION OF ROOF PANELS.**

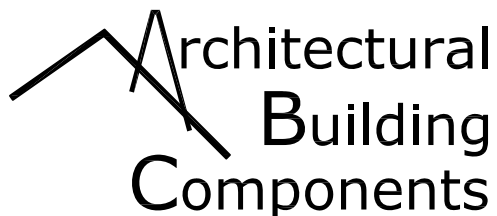

11625 N. HOUSTON ROSSLYN RD.  
HOUSTON, TX. 77086  
www.archmetalroof.com

(281) 931-3986  
(800) 423-1105  
FAX: (281) 931-3989

PANEL:



238T STANDING SEAM PANEL

DETAIL:

CURB DETAIL-OVER PLYWOOD

DATE:

05/05/09

DET. #

238T-CURB